

Operating instructions Needle ionizer NI



Operating instructions Needle ionizer NI



Air Line





Types:	Needle ionizer NI single	Ø 6 mm
		Ø 8 mm
	Needle ionizer NI multiple	Ø 6 mm
		Ø 8 mm

Keep in a safe place for future reference!

Contents

- | | |
|------------------------------------|----------------------------|
| 1. Notes on operating instructions | 5. Remedy of defects |
| 2. Safety | 6. Maintenance and repairs |
| 3. Installation | 7. Technical data |
| 4. Application | |

1 Notes on operating instructions

In these operating instructions, the needle ionizer NI is also referred to as "unit" or "ionizing unit".

1.1 Pictorial markings used

In these operating instructions



Caution!
Important instructions!



Danger!
High voltage!
Danger of fatal accidents!



**Switch off the power pack before connecting
or disconnecting the coaxial connectors!**

In the operating instructions and on the unit



Danger!
High voltage!
Danger of fatal accidents!

2 Safety

The unit is operationally safe, provided that it is operated in accordance with its intended use. In case of misuse, dangers may result:

- For life and limb of the operator,
- For the unit and other assets.

Also note Chapter 3.1 (Important installation notes).



Special safety instructions apply to operators with heart pacemakers; please apply to HAUG for details!

2.1 Intended use

The unit generates positive and negative ions.

The units assist the air stream and are intended to eliminate electrostatic charges and contamination (e.g. dust) from paper, films and foils, textiles, glass, plastics etc.

HAUG power packs only must be used for supplying the high voltage to the units.



Do not install or use the units in areas subject to explosion hazards.

For reasons of safety, unauthorized conversions and modifications of the unit are not permitted. The installation and operating conditions indicated in these Operating Instructions must be adhered to.

2.2 Danger sources

Defective high-voltage plugs and cables may lead to danger of electric shocks. Shut down the unit immediately in case of visible damage and suspected electrical defects.



Never use air-assisted ionizers without pressure reducers and compressed air filters (refer to "Accessories")!

Never exceed the permitted maximum pressure (see "Technical data")!

Secure air hoses with suitable clamps!



Danger!
High voltage!
Danger of fatal accidents!
Do not open unit!



Only plug in/unplug coaxial connector when the unit is switched off!

2.3 Operator qualifications

The unit may be installed and put into operation by trained electricians only or by authorized and persons informed about the potential dangers. The above mentioned persons must have read the operating instructions and must follow the instructions, notes and safety advice. The above-mentioned persons must have been instructed in the installation and handling of compressed air units and resulting dangers.

3 Installation

The unit may be installed by trained electricians only and by authorized persons informed about the potential dangers. The above mentioned persons must have read the operating instructions and must follow the instructions, notes and safety advice. The above-mentioned persons must have been instructed in the installation and handling of compressed air units and resulting dangers.

1. Install unit.
2. Connect to air supply system.
3. Connect air suction (only single NI).
4. Connect unit to power pack.

3.1 Important installation instructions

The operation of the unit is not affected by the position in which it is installed.



Never use air-assisted ionizers without pressure reducers and compressed air filters (refer to "Accessories")!

Never exceed the permitted maximum pressure (see "Technical data")!

Secure air hoses with suitable clamps!



Do not connect the units to the power pack until installation is completed.

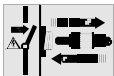

Switch off the power pack before connecting or disconnecting the coaxial connectors!

3.2 Ionizing units

The numerals refer to the illustration at the end of these instructions.

1

Needle ionizer NI single.

2

Needle ionizer NI multiple.

3

Install high-voltage cables without kinks. Smallest bending radius 50 mm.

4 Application

The unit may be put into operation by trained electricians only or by persons instructed in the potential dangers. The above mentioned persons must have read the operating instructions and must follow the instructions, notes and safety advice. The above-mentioned persons must have been instructed in the handling of compressed air units and resulting dangers.

Conditions:

The power pack and the ionizing unit must be connected correctly.

The ionizing units are used in connection with compressed air and HAUG power packs to eliminate electrostatic charges and contamination (e.g. dust) from paper, films and foils, textiles, glass, plastics etc.

Principle: Needle ionizer NI single.

Figure 1: Discharging and cleaning filling vessels, injection needles and bottles before filling.

1. Suction nozzle
2. Air connection
3. High-voltage connection

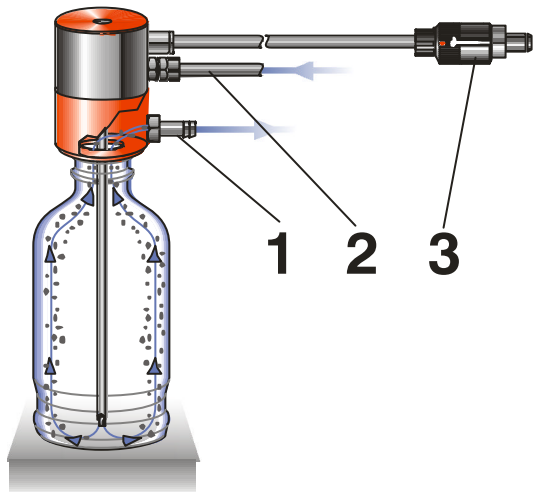

Figure 1

4.1 Putting into operation

1. Switch on compressed air supply.
2. Switch on air suction (only single NI).
3. Switch on power pack.

5 Remedy of defects

Any remedy of defects must be carried out by trained electricians only. The above mentioned persons must have read the operating instructions and must follow the instructions, notes and safety advice. The above-mentioned person must have been instructed in the installation and handling of compressed air units and resulting dangers.

In case of defects regarding the power pack and the ionizing unit, please check for correct installation first. If this does not solve the problem, please return the power pack together with the ionizing unit for examination.



Danger!
High voltage!
Danger of fatal accidents!



***Switch off the power pack before connecting
or disconnecting the coaxial connectors!***

6 Maintenance and repairs



Danger!
High voltage!
Danger of fatal accidents!

This unit does not include any parts which can be repaired by the operator.

Should the unit prove defective or if a defect is suspected, switch off unit immediately and secure against subsequent reuse.

6.1 Accessories

Compressed air service station 3/4"
Compressed-air hose

11.7210.001
X – 6607

7 Technical data

7.1 Supply voltage

The ionizing units are provided with high voltage from HAUG power packs.

7.2 Compressed air

Maximum pressure		6 bar, free of oil and aerosols
Air consumption	Ø 6 mm	62 l/min at 6 bar
	Ø 8 mm	230 l/min at 6 bar

7.3 Ambient conditions

Ambient temperature:

Rated application range	+5 °C to +45 °C
Extreme range for storage and transport	-15 °C to +60 °C

Humidity:

Rated application range	20 % to 65 % RH
Extreme range for storage and transport	0 % to 85 % RH

7.4 Dimensions

	Cross-section	Length
High-voltage cable	Ø 10 mm	customer-specific
Compressed-air hose	Ø 8 mm	customer-specific
Injection electrode	Ø 6 mm	customer-specific
Injection electrode	Ø 8 mm	customer-specific

1

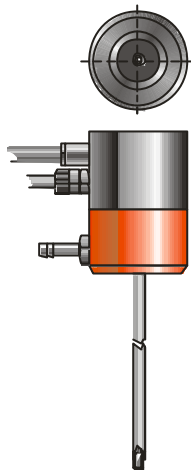

2

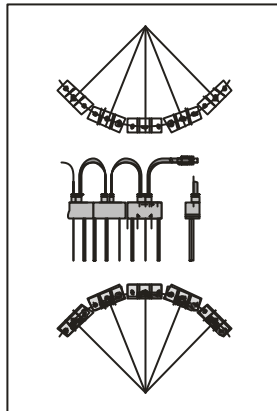

3

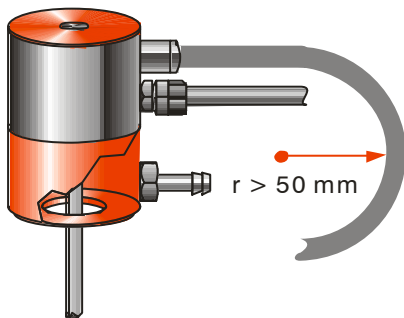







made by



HAUG GmbH & Co.KG

Friedrich-List-Straße 18
D-70771 Leinfelden-Echterdingen
Telefon 07 11 / 94 98 - 0
Telefax 07 11 / 94 98 - 298

www.haug.de
E-Mail: info@haug.de

HAUG Biel AG

Postfach 52
CH-2500 Biel/ Bienne 6
Johann-Renfer-Strasse 60
CH-2500 Biel/ Bienne 6
Telefon 0 32 / 3 44 96 96
Telefax 0 32 / 3 44 96 97

www.haug.de
E-Mail: haug@bluewin.ch